



US00D778753S

(12) **United States Design Patent**  
**Selevan**

(10) **Patent No.:** **US D778,753 S**

(45) **Date of Patent:** **\*\* Feb. 14, 2017**

- (54) **ELECTRONIC TRAFFIC SAFETY/GUIDANCE FLARE**
- (71) Applicant: **PI VARIABLES, INC.**, Laguna Beach, CA (US)
- (72) Inventor: **James R. Selevan**, Laguna Beach, CA (US)
- (\*\*) Term: **14 Years**

7,182,479 B1 \* 2/2007 Flood ..... F21L 4/00 362/157  
 7,563,158 B2 7/2009 Haschke et al.  
 D631,582 S \* 1/2011 Hwang ..... D26/24  
 8,072,345 B2 \* 12/2011 Gallo ..... B60Q 1/52 340/472  
 D654,387 S \* 2/2012 Wilson ..... D10/114.2  
 8,154,424 B2 4/2012 Selevan  
 D678,100 S \* 3/2013 Hwang ..... D10/114.1  
 (Continued)

- (21) Appl. No.: **29/525,453**
- (22) Filed: **Apr. 29, 2015**
- (51) **LOC (10) Cl.** ..... **10-05**
- (52) **U.S. Cl.**  
USPC ..... **D10/114.1**
- (58) **Field of Classification Search**  
USPC ..... D10/114.1, 114.3, 109.1, 113.1, 114.2; D26/24  
CPC ..... B60Q 7/00; B60Q 1/52; F21L 4/00; F21L 4/02  
See application file for complete search history.

**OTHER PUBLICATIONS**

Finley, M.D. et al., "Sequential Warning Light System for Work Zone Lane Closures," Texas Transportation System, (2011) pp. 1-23.

(Continued)

*Primary Examiner* — George D Kirschbaum  
(74) *Attorney, Agent, or Firm* — Robert D. Buyan; Stout, Uxa & Buyan, LLP

(57) **CLAIM**

The ornamental design for an electronic traffic safety/guidance flare, as shown.

(56) **References Cited**  
**U.S. PATENT DOCUMENTS**

3,500,378 A	3/1970	Pickering et al.	
3,787,867 A	1/1974	Dodge et al.	
4,132,983 A	1/1979	Shapiro	
4,827,245 A	5/1989	Lipman	
4,841,278 A	6/1989	Tezuka et al.	
5,438,495 A	8/1995	Ahlen et al.	
6,486,797 B1 *	11/2002	Laidman	B60Q 7/00 340/332
D498,164 S *	11/2004	Delich	D10/114.3
6,929,378 B2	8/2005	Wang	
D515,958 S *	2/2006	Dueker	D10/109.1
7,088,222 B1 *	8/2006	Dueker	B60Q 7/00 340/321

**DESCRIPTION**

FIG. 1 is a left perspective view of an embodiment of an electronic traffic safety guidance flare; FIG. 2 is a right side view of the embodiment of FIG. 1; FIG. 3 is a left side view of the embodiment of FIG. 1; FIG. 4 is a front view of the embodiment of FIG. 1; FIG. 5 is a rear view of the embodiment of FIG. 1; FIG. 6 is a top view of the embodiment of FIG. 1; and, FIG. 7 is a bottom view of the embodiment of FIG. 1.

**1 Claim, 4 Drawing Sheets**

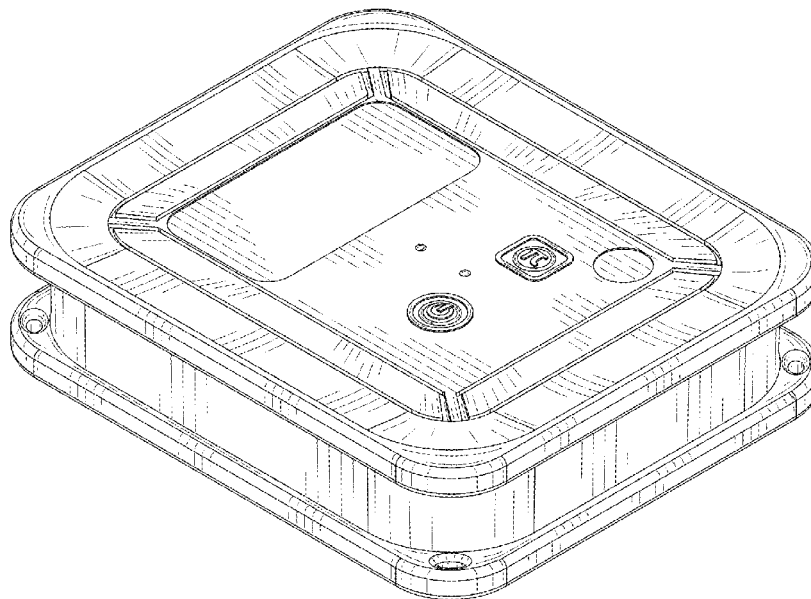

(56)

**References Cited**

U.S. PATENT DOCUMENTS

8,564,456	B2	10/2013	Selevan	
9,437,109	B1*	9/2016	Stafford .....	F21L 4/02
2002/0154787	A1	10/2002	Rice et al.	
2002/0175831	A1	11/2002	Bergan et al.	
2003/0164666	A1	9/2003	Crunk	
2004/0056779	A1	3/2004	Rast	
2004/0100396	A1	5/2004	Antico et al.	
2005/0040970	A1	2/2005	Hutchins et al.	
2006/0072306	A1	4/2006	Woodyard	
2007/0038743	A1	2/2007	Hellhake et al.	
2007/0194906	A1	8/2007	Sink	
2007/0222640	A1	9/2007	Guelzow et al.	
2008/0042866	A1	2/2008	Morse et al.	
2008/0091304	A1	4/2008	Ozick et al.	
2009/0115336	A1	5/2009	Wang	
2009/0187300	A1	7/2009	Everitt	
2013/0271294	A1	10/2013	Selevan	
2013/0293396	A1	11/2013	Selevan	
2014/0210373	A1	7/2014	Baret	

OTHER PUBLICATIONS

Sun, C. et al., "Cost-Benefit Analysis of Sequential Warning Lights in Nighttime Work Zone Tapers", University of Missouri, Report to the Smart Work Zone Deployment Initiative, Jun. 6, 2011.  
Internet Website Screen Capture, [www.empco-lite.com](http://www.empco-lite.com); Sep. 6, 2010.

\* cited by examiner

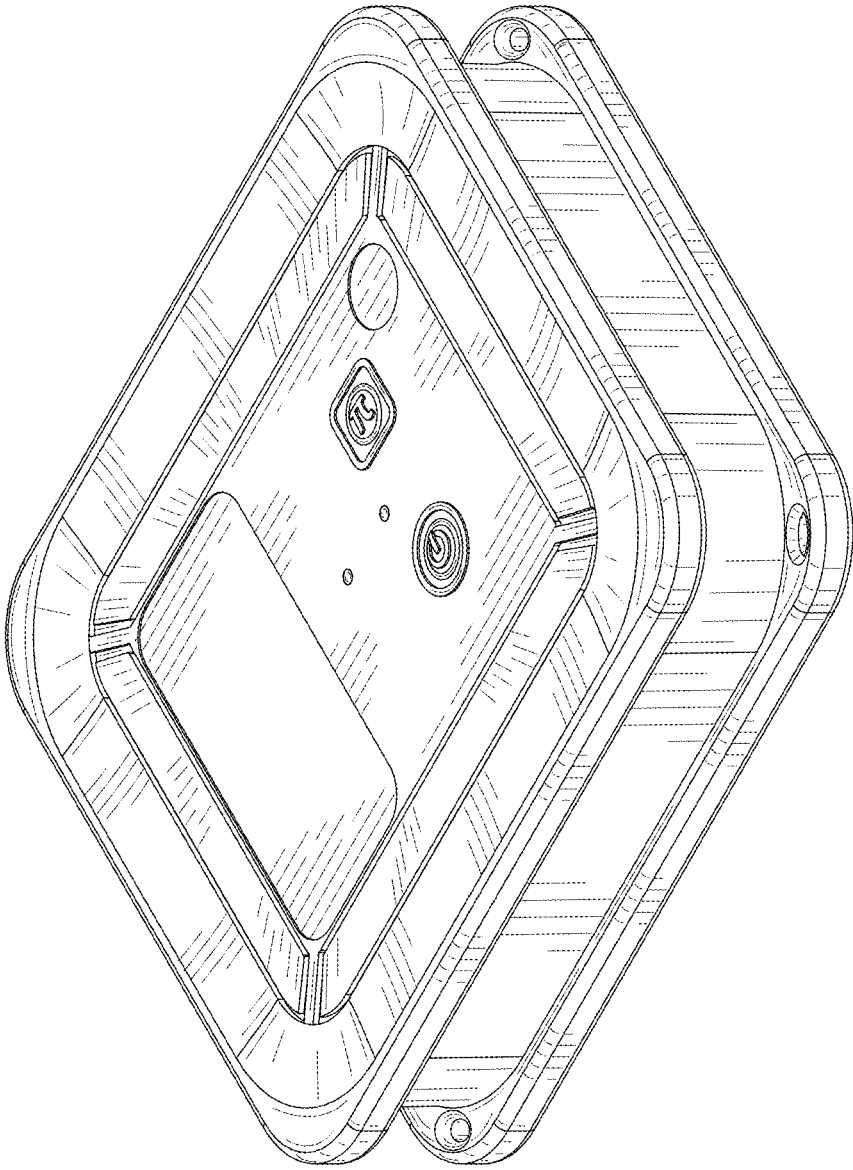

FIG. 1

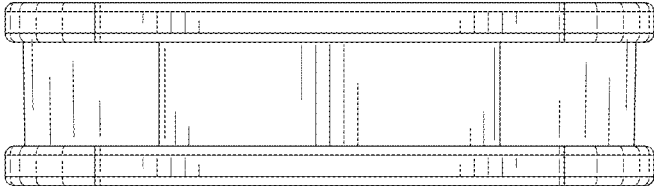

FIG. 2

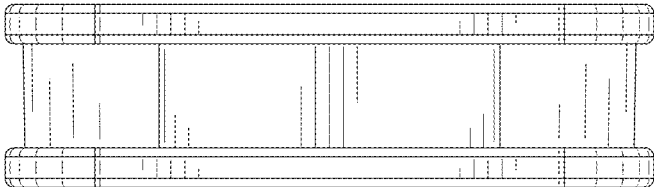

FIG. 3

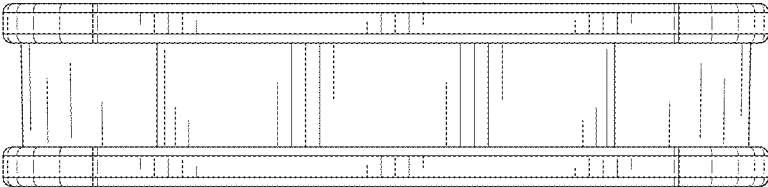

FIG. 4

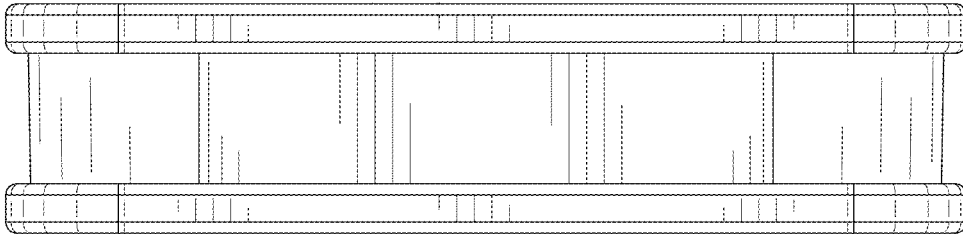

FIG. 5

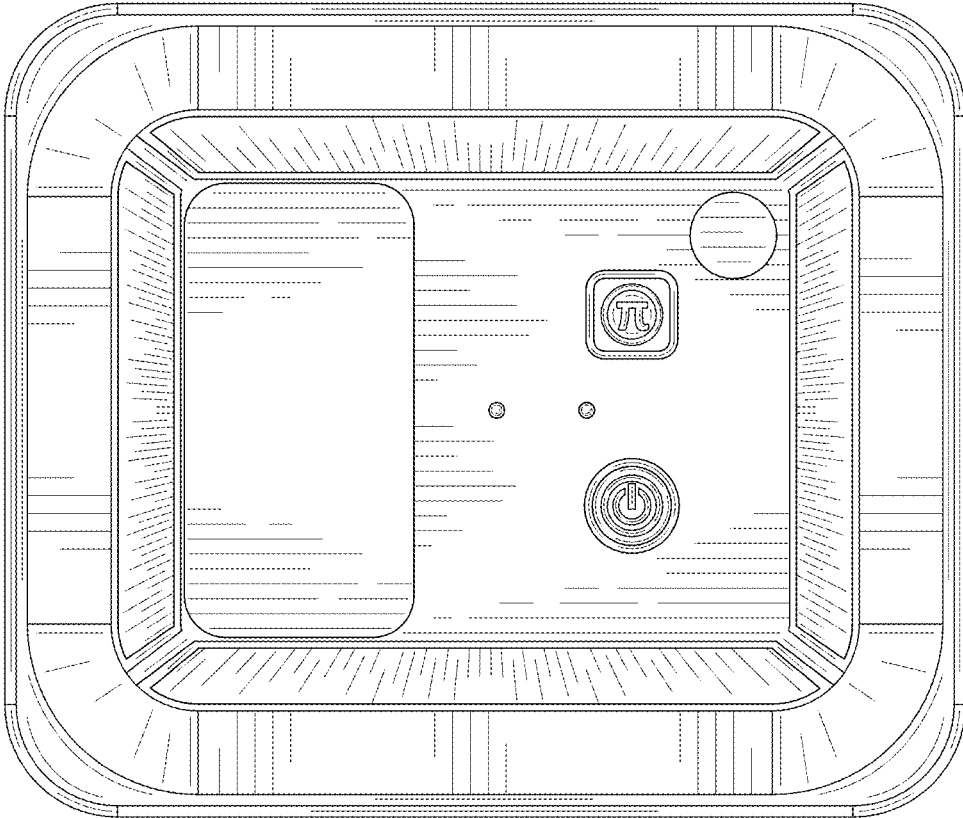

FIG. 6

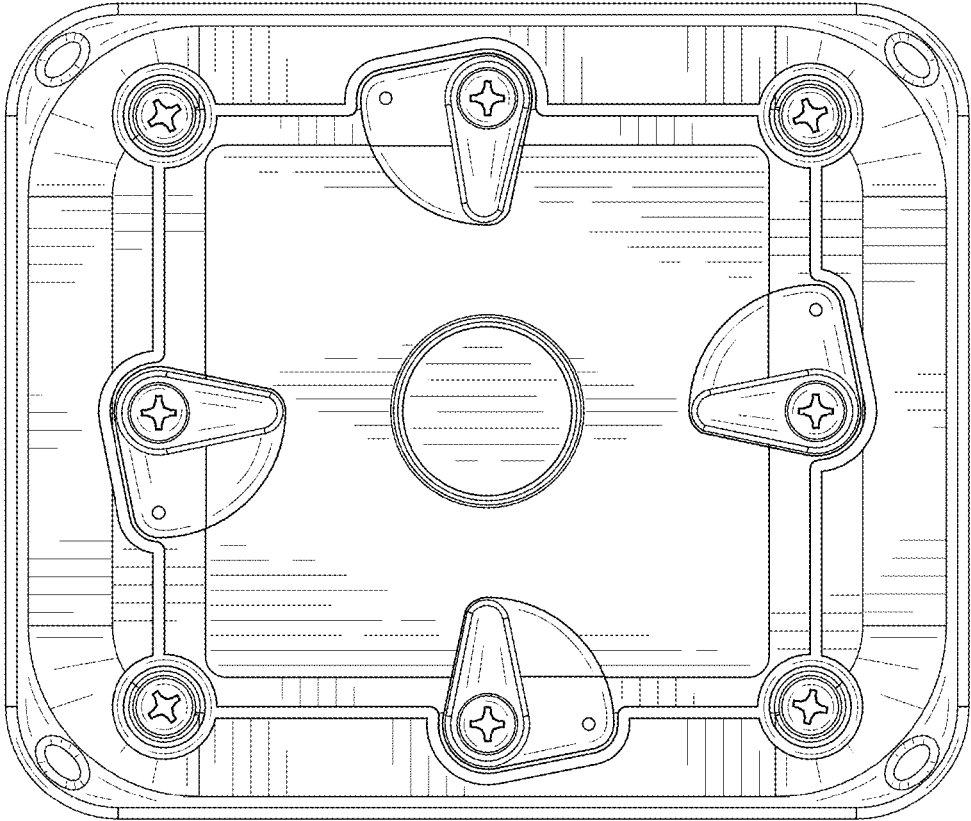

FIG. 7